

**1st**  
Edition

Mastering PLM Selection with

# Practical RFP Templates

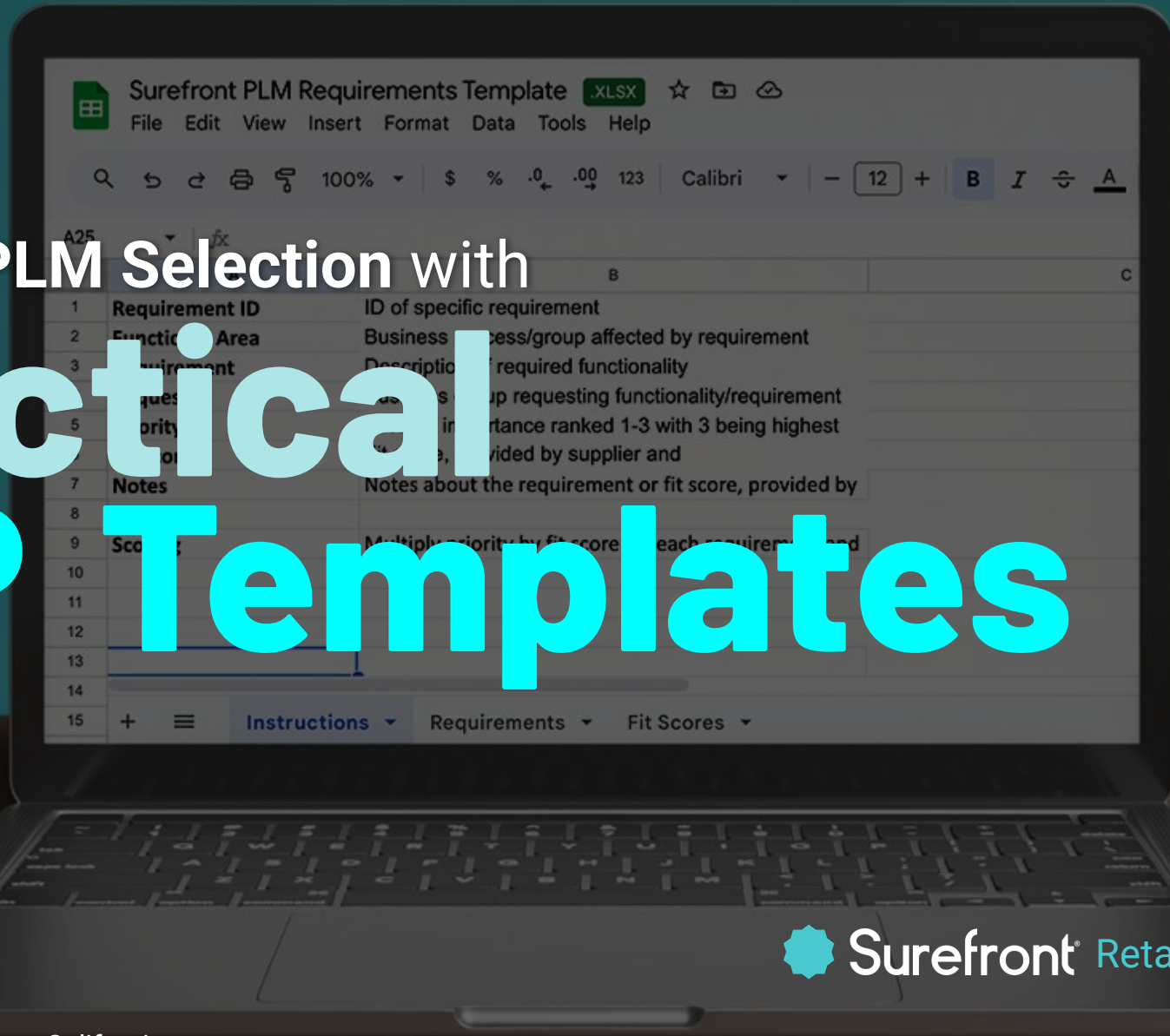

 **Surefront** Retail Guides

© 2024 Surefront | Pasadena, California.

All rights reserved. Surefront is a registered trademark of Sure Market, LLC. For more information, email [info@surefront.com](mailto:info@surefront.com) or visit [surefront.com](https://surefront.com).

# Your Blueprint for PLM Success

Selecting the right **Product Lifecycle Management** (PLM) software is one of the most critical decisions your business will make. Yet, for many teams, the **process can feel overwhelming**. Relying on **outdated tools** like **spreadsheets** and **email** leads to miscommunication, scattered data, and costly delays - putting growth and innovation at risk.

This guide is here to solve that. By using a structured Request for Proposal (RFP) process, you eliminate the guesswork. An RFP clarifies your needs, aligns your team, and ensures you evaluate PLM vendors objectively. **The result?** Confidence in choosing a PLM that solves your challenges, scales with your business, and sets you up for measurable success.

This guide isn't about software; it's about solving real business problems. With **Surefront's RFP** framework, you can confidently navigate the PLM selection process and make a decision that drives growth and efficiency for years to come.

# What's Inside:

Page 4



**Selecting the Best PLM**

Page 9



**The Best PLM Step-by-Step**

Page 16

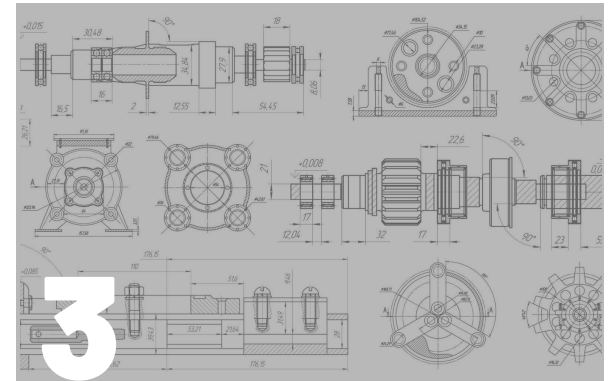

**A Blueprint for PLM Success**

Chapter 1

# Selecting the Best PLM

# Choose the right PLM by knowing your challenges.

Many merchandising teams hit a wall when outdated tools - like spreadsheets, emails, and disconnected systems - create more problems than they solve. The first step in your PLM journey is to document those struggles and translate them into a practical RFP.



**JIA HOME**, a fast-growing home decor brand, faced delays from scattered supplier communication and data errors. Using an RFP to prioritize collaboration tools, they reduced **supplier response times by 30%** and sped up product launches.

## Define Your Needs and Challenges

---

Are product approvals delayed because of miscommunication?

---

Is your product data scattered across multiple tools and silos?

---

Are your teams overwhelmed by manual tasks that could be automated?

---

# Drafting a Strong RFP

By **crafting a detailed RFP**, you eliminate ambiguity and empower vendors to demonstrate how their solutions align with your goals. [Surefront's RFP template](#) simplifies this process, providing you with pre-structured frameworks that ensure every critical question is covered.

In short, a **well-written RFP** helps you focus on solutions - not sales pitches. It sets the tone for a thoughtful, results-driven vendor selection process.

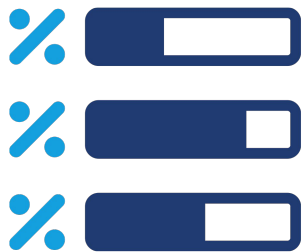

## Business Goals

What outcomes do you want to achieve?  
Faster time-to-market? Better collaboration?  
Lower error rates?



## Core Requirements

Highlight must-have features, such as centralized data, flexible workflows, and seamless integrations.



## Evaluation Criteria

Define how you'll assess vendors.  
Focus on usability, scalability, and post-implementation support.

# Big Brands Getting it Right

Global leaders have leveraged PLM systems to transform their workflows and achieve measurable results.



**Amazon** streamlined product development and vendor management across its global supply chain. By centralizing product data with PLM, they reduced product launch timelines and eliminated silos.



**Apple** enhanced collaboration between design, production, and supply chain teams, enabling rapid product innovation while maintaining exceptional quality.



**Walmart**  
Save money. Live better.

**Walmart** improved product lifecycle visibility by consolidating supplier communication and product data into one system, reducing delays and enhancing inventory planning.

# Industry Specific Examples



## Automotive

A scalable PLM can efficiently manage complex supply chains involving numerous SKUs and global suppliers. For example, automakers can integrate supplier data, production schedules, and regulatory compliance in one system. This reduces delays and enhances inventory management across multiple regions, streamlining the entire supply chain.



## Electronics

PLM systems track component sourcing, ensuring parts meet strict safety regulations and quality standards. Electronics companies can use PLM to automate compliance documentation, streamline product design revisions, and reduce the risk of regulatory fines. This results in smoother production cycles and fewer regulatory bottlenecks.



## FMCG (Fast-Moving Consumer Goods)

PLM accelerates product launches by simplifying packaging design, ingredient sourcing, and regulatory approvals. For instance, FMCG brands can bring seasonal products to market faster while maintaining compliance with regional standards. This increased agility boosts competitiveness and responsiveness to market demands.





Surefront PLM Requirements Template .XLSX

File Edit View Insert Format Data Tools Help

100% | \$ % .0 .00 123 | Calibri | - 12 + | B I U A

A25

	A	B	C
1	<b>Requirement ID</b>	ID of specific requirement	
2	<b>Functional Area</b>	Business process/group affected by requirement	
3	<b>Requirement</b>	Description of required functionality	
4	<b>Requestor</b>	Business group requesting functionality/requirement	
5	<b>Priority</b>	Level of importance ranked 1-3 with 3 being highest	



# DOWNLOAD THE RFP

11			
12			
13			
14			
15	+	☰	Instructions ▾ Requirements ▾ Fit Scores ▾

Chapter 2

# The Best PLM Step-by-Step

# Outdated Tools Are Costing You Growth

Before you can select the right PLM, you need to **recognize when your current processes are falling short**. Often, the “status quo” becomes the biggest obstacle to progress.

Businesses cling to manual tools - like **spreadsheets and PDFs** - because they're familiar, even when those tools create inefficiencies. Here's how to identify the turning points that signal you're ready for a PLM system.



## Outdated Tools Are Holding You Back

Reliance on **spreadsheets** and **emails** causes poor teamwork and delays. **IKEA cut development timelines by 18%** and sped up market responses by adopting a unified PLM system.



## Overwhelmed Teams Can't Innovate

Wasted time on data and errors stifles growth. **Adidas** solved this with an RFP for centralized data, adopting a PLM that **boosted productivity by 35%** and freed teams to innovate.



## Data Silos Stall Progress

Scattered data hinders collaboration. **Unilever used PLM to unify global product data**, improving communication and cutting time-to-market by **20%**.



## Scaling Becomes Impossible

Growing product lines and suppliers overwhelm manual processes. **Patagonia** adopted a scalable **PLM to expand efficiently** while supporting eco-conscious development. A focused RFP helps address challenges and find solutions that deliver results.

# Real-World Examples



## Streamlining Data and Scaling Operations

**JIAHome** overcame errors and delays from scattered data by using a structured RFP to prioritize centralized storage and scalability. The result? A **40% reduction** in data retrieval time and seamless catalog expansion.



## Enhancing Collaboration for Jewelry Design

**Bony Levy**, a fine jewelry brand, replaced spreadsheets with a PLM solution found through a strategic RFP. This improved supplier communication and cut **design to production timelines by 25%**, enabling faster seasonal launches.



## BAUBLEBAR

## Scaling Fast-Growth Product Development

**BaubleBar** overcame bottlenecks from manual processes by using an RFP to find a scalable PLM. The solution centralized data, streamlined SKUs, and improved supplier collaboration, **cutting time-to-market by 30%**.



# The Impact

## Without an RFP

Chaotic, delayed processes  
Miscommunication and gaps  
Overlapping, unclear tools

VS

## With an RFP

30% faster implementation  
40% fewer errors  
**Clear** vendor comparison

Reduced Onboarding Time

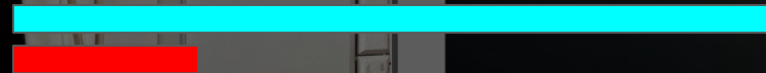

Faster Time-to-Market

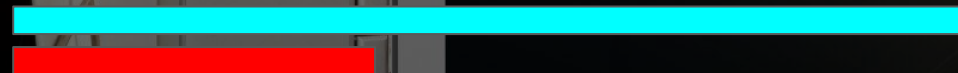

Fewer Errors



0 15% 20% 25% 30% 40% 50%

## A Clear RFP Eliminates Guesswork

It allows businesses to align their challenges with a vendor's capabilities, making selection smoother and results-driven.

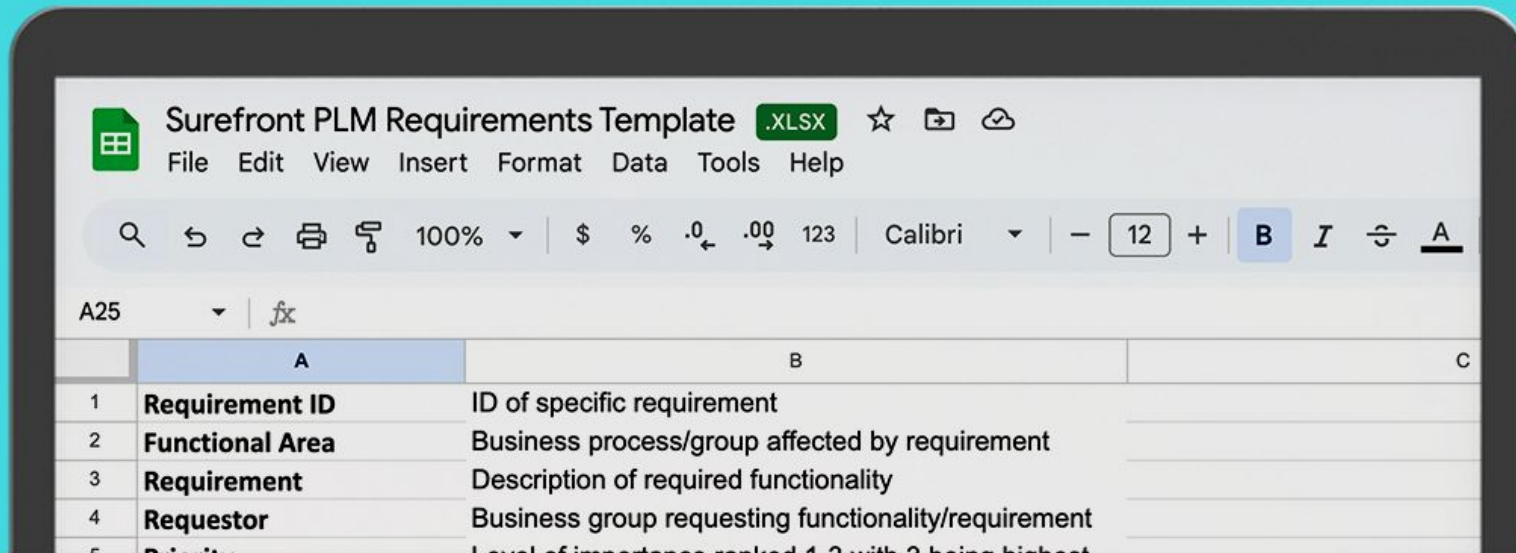
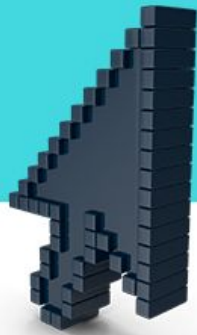

# TRY IT FREE

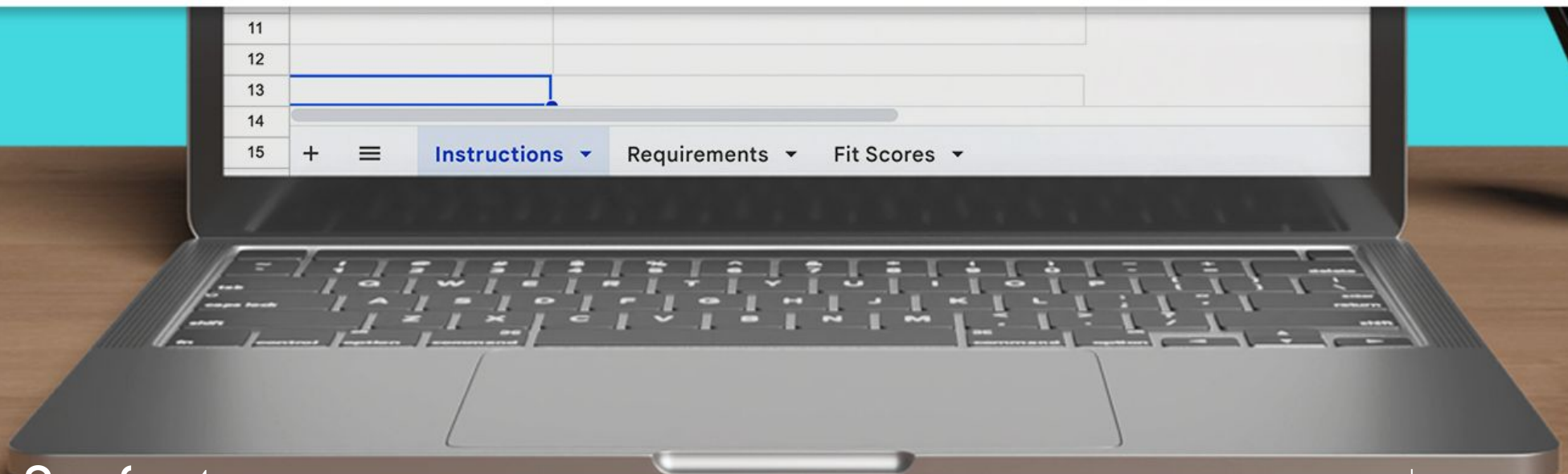

Chapter 3

# A Blueprint for PLM Success



# Find the Right PLM Vendor by Leveraging a Strategic RFP

With a **well-crafted RFP** and a clear understanding of your challenges, the next step is evaluating vendors. The key is to focus on **practical, real-world success** factors that align with your business goals.



## Evaluate Vendor Support

A great PLM partner ensures your success. Ask about post-implementation support and service plans. **Nike** cut **onboarding time by 30%** by choosing a vendor with a hands-on support model.



H O M E

## Prioritize Scalability

Your PLM should grow with your business. Ask about scaling for SKUs, suppliers, and product lines. **JIA Home expanded its catalog by 40%** in two years with a scalable PLM found through a focused RFP.

S E P H O R A

## Focus on Usability

The best PLM systems prioritize usability with intuitive interfaces, flexible workflows, and strong onboarding. **Sephora** chose a user-friendly PLM, boosting supplier collaboration and **cutting production delays by 15%**.

**Surefront's template** simplifies comparisons, helping your team make confident, data-driven decisions.

# Your Roadmap to PLM Success

Selecting a [PLM system](#) is a transformative decision for your business, but it doesn't have to be a daunting one.

A well-structured [RFP](#) gives you clarity, alignment, and a clear path forward. By focusing on your business needs, identifying your challenges, and evaluating vendors with precision, you'll find a PLM that streamlines operations and empowers growth.

[Surefront's practical RFP Template](#) simplifies this process, helping businesses like yours ask the right questions, evaluate responses effectively, and make confident decisions. **The result?** A PLM solution that eliminates inefficiencies, enhances collaboration, and grows alongside your business.

Don't let outdated tools hold you back. [Start your PLM journey today](#) with a clear plan and the confidence that you're making the right choice.

Scan to Download  
The PLM RFP!



# Surefront<sup>®</sup>

## Transform Your PLM RFP Process Today!

## Find the Perfect PLM with the Right RFP

Surefront simplifies the **RFP process**, empowering your business to identify the **perfect PLM solution** with ease. By aligning with best practices, our tools help you create professional, impactful RFPs that ensure you select a system tailored to your needs.

**Define Clear Requirements:** Structure your RFP to focus on critical features like centralizing product data and enhancing team collaboration.

**Highlight Key PLM Capabilities:** Pinpoint solutions that streamline product management, from development to distribution.

---

### Ready to see the Surefront difference?

Learn More by [Booking a demo](#) with one of Surefront's product collaboration experts today

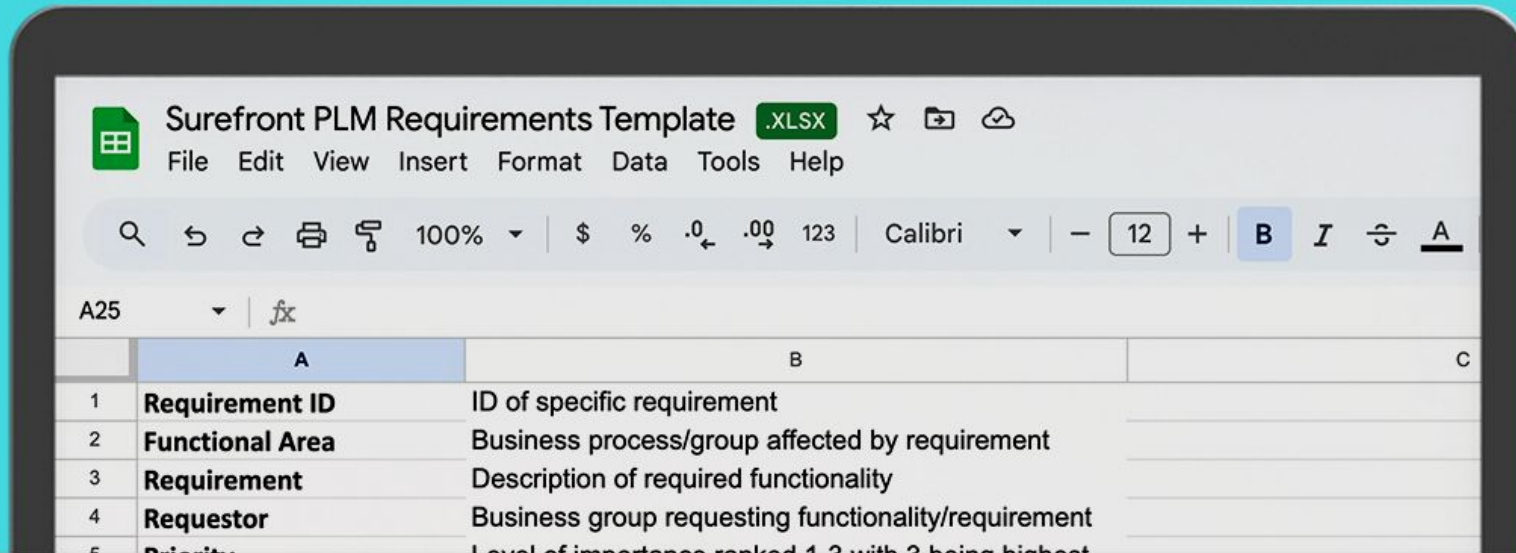
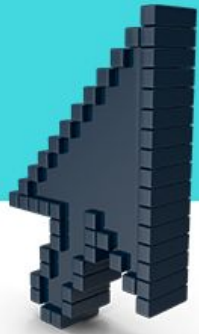

# BOOK A DEMO

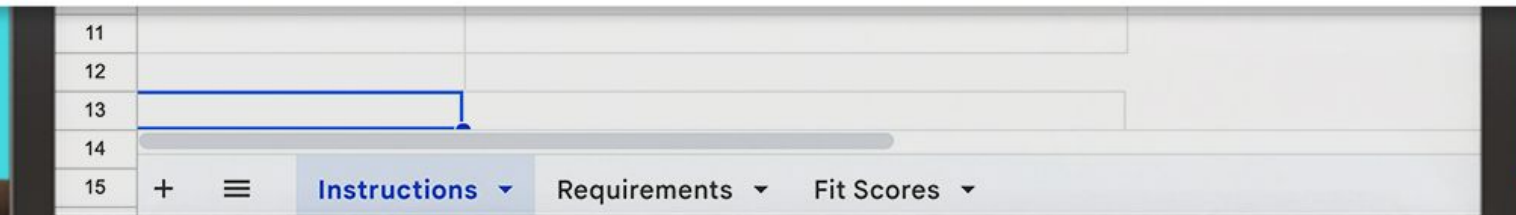

# Guides and Resources



**DOWNLOAD TODAY**



# Recommended for You

**Article:** [Transforming Your Catalog Management with PIM](#)

**Article:** [Catalog Management with a Centralized Approach](#)

**Article:** [The Key Metrics for Catalog Success](#)

**Article:** [Evolve Your Product Catalog into a Powerful Tool for Growth](#)

**Article:** [Will Slow Fashion Impact Consumer Expectations?](#)

**Article:** [The Most Popular Raw Materials in Fashion Today](#)

**Article:** [Calm The Chaos of the Retail Buying Process Pt 1: Retail is a Symphony](#)

**Case Study:** [How Surefront Helped JIA Home Achieve 150% Increase in Revenue Per Employee](#)

**Guide:** [The Complete Guide to Product Lifecycle Management Software](#)

**Get notified** when the next version of this free guide is available for download.

**Sign up here** to stay on top of news & trends in the B2B retail industry!

# Sources

1. Home Depot [Supplier Guidelines for PLM Integration](#)
2. Apps Run The World [Nike Technographics](#)
3. Gartner (2024) [PLM Software in Discrete Manufacturing Industries](#)
4. McKinsey & Company (2024) [The State of Fashion 2024](#)
5. Centric (2023) [Why Integrations To PLM Are Driving Digital Transformation In Fashion](#)
6. Retail Dive (2022) [Why Small Fashion and Retail Businesses Should Embrace Product Lifecycle Management](#)
7. McKinsey & Company (2024) [Fashion's Digital Transformation: Now or Never](#)
8. Gartner (2024) [Magic Quadrant for Contract Life Cycle Management](#)
9. DocuSign (2024) [DocuSign Named a Leader in the 2024 Gartner® Magic Quadrant™ for Contract Life Cycle Management](#)
10. Gartner (2024) [Magic Quadrant for Contract Life Cycle Management](#)



# 3 Solutions. 1 Unified Platform.

[Follow us on LinkedIn](#) | [sales@surefront.com](mailto:sales@surefront.com)

**Learn more about us** at [surefront.com/sales](https://surefront.com/sales)